



DYNACO
High Performance Doors



DYNACO S-545

Cat.3 Atex

Power

Push-Pull
gear driven technology



outside door

DYNACO S-545 Cat.3 Atex Power

The Dynaco S-545 Cat.3 Atex Power is specifically designed for outside applications in explosion sensitive environments. Officially approved by Apragaz notified body for use in potentially explosive atmospheres. All metal parts are stainless steel, non-metallic parts are composed of antistatic or electrical conductive materials, thus avoiding the build up of static electricity that could generate sparks. Operating speed and perfect sealing properties improve your traffic flows and provide employee comfort, environmental control and savings on energy costs. Fully self-reinserting, the Dynaco S-545 Cat.3 Atex Power will automatically reinsert itself in its side guides when the curtain is accidentally hit.

- **HIGH SPEED OPERATION:**
Maximum speed 1 m/s.
- **PATENTED "PUSH PULL" TECHNOLOGY:**
Unique door drive system.
- **SUPERIOR SEAL, WIND RESISTANT:**
Patented side frame assembly.
Up to wind load class 4.
- **CRASH FORGIVING AND SELF-REINSERTING WITHOUT INTERVENTION:**
The curtain automatically reinserts itself when dislodged. No repair costs, no production downtime.
- **USER SAFETY:**
Flexible curtain without rigid elements.
- **ADVANCED DRIVE:**
Frequency driven motor and encoder for smooth operation. Wearable elements are reduced to a minimum.
- **DYNALOGIC CONTROL BOX:**
User-friendly control box with self-diagnosis.
- **CONFORM TO EN13241-1**
- **CONFORM TO DIRECTIVE 2014/34/EU**
Ex II 3 G Ex db eb h ia mc IIC T4 Gc
Ex II 3 D Ex h ia mc tb IIIB T135°C Dc
CE 0029 APRAGAZ 20ATEX0205 X
T ambient -10°C to 45°C



All synthetic parts
in antistatic material



Side reinforcement



Complete structure
in stainless steel





EN13241-1 STANDARDS

Standard	Ref.	Test acc.	Results
Water permeability	EN 12425	EN 12489	Class 2
Wind load	EN 12424	EN 12444	Class 3*
Wind permeability	EN 12426	EN 12427	Class 1**
Safe openings	EN 12453	EN 12445	Pass
Mechanical resistance	EN 12604	EN 12605	Pass
Unintended movements	EN 12604	EN 12605	Pass
Thermal transmittance	EN 12428	EN 12428	6,02 W/m ² K
Performance (cycles)	EN 12604	EN 12605	NPD

The indicated class for wind resistance applies for maximum dimensions.

* For doors up to W 4.000mm x H 5.500mm: Class 4

** Valid for a door of 3500 x 3500mm

Explosion groups	Temperature class					
	T1	T2	T3	T4	T5	T6
Min. ignition temperature or max. surface temperature	450 °C	300 °C	200 °C	135 °C	100 °C	85 °C
I (Mining)	Methane					
IIA	Acetone Ammonia Benzene Acetic acid Ethane Ethyl acet. Methane Methanol Naphtalene Phenol Propane	i-Amylac- etate n-Butane n-Butane alcohol	Benzines Diesel fuels Fuel oils n-Hexane	Acetaldehyde		
IIB	Town gas	Ethylene Ethylene oxide	Hydrogen sulphide	Ethyl ether		
IIC	Hydrogen					Carbon disul- phide

CHARACTERISTICS

Max. dimensions	W 5.500 mm x H 5.500 mm
Opening speed Closing speed	Maximum 1 m/s 1 m/s
Structure	Stainless steel: 80 x 40 x 3 mm.
Drum	Stainless steel - Ø 102 x 1.2 mm.
Side guides	Reinforced antistatic polyethylene (PE-UHMW1000 carbon black) on springs. Lower 300 mm of side guides reinforced.
Motor	4 poles, without brake. Ex d Power 1,5 kW - IP rating: IP 66
Control box	DYNALOGIC 2 (600x600x210mm) provided with: circuit breaker, general divider, adjustable timer, push button for opening and reset, emergency stop and Ex i switching amplifier. IP rating: IP 65. Frequency inverter. Always to be installed outside the danger zone. Optional: DYNALOGIC 5 (500x500x250mm).
Standard detectors	Ex ia infrared barrier: 300 mm from the floor. Bottom edge detection via intrinsic safety barrier
Power supply Frequency	Single phase 230V - 16 A Frequency: 50-60 Hz
Available colours comparable with:	Black RAL9005  (Actual colour may deviate. Colour sample available upon request)

Atex motor, gearbox and encoder

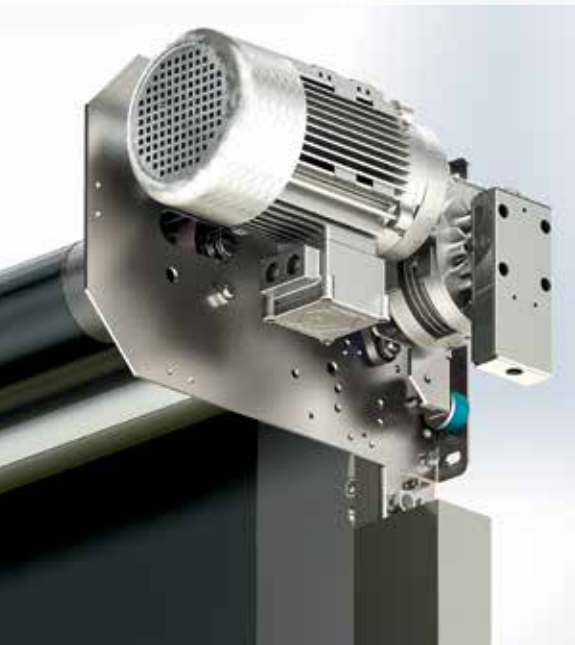

Bottom edge detection via intrinsic safety barrier



Standard earthing kit



Dimensions and installation requirements Dynaco S-545 Cat.3 Atex Power

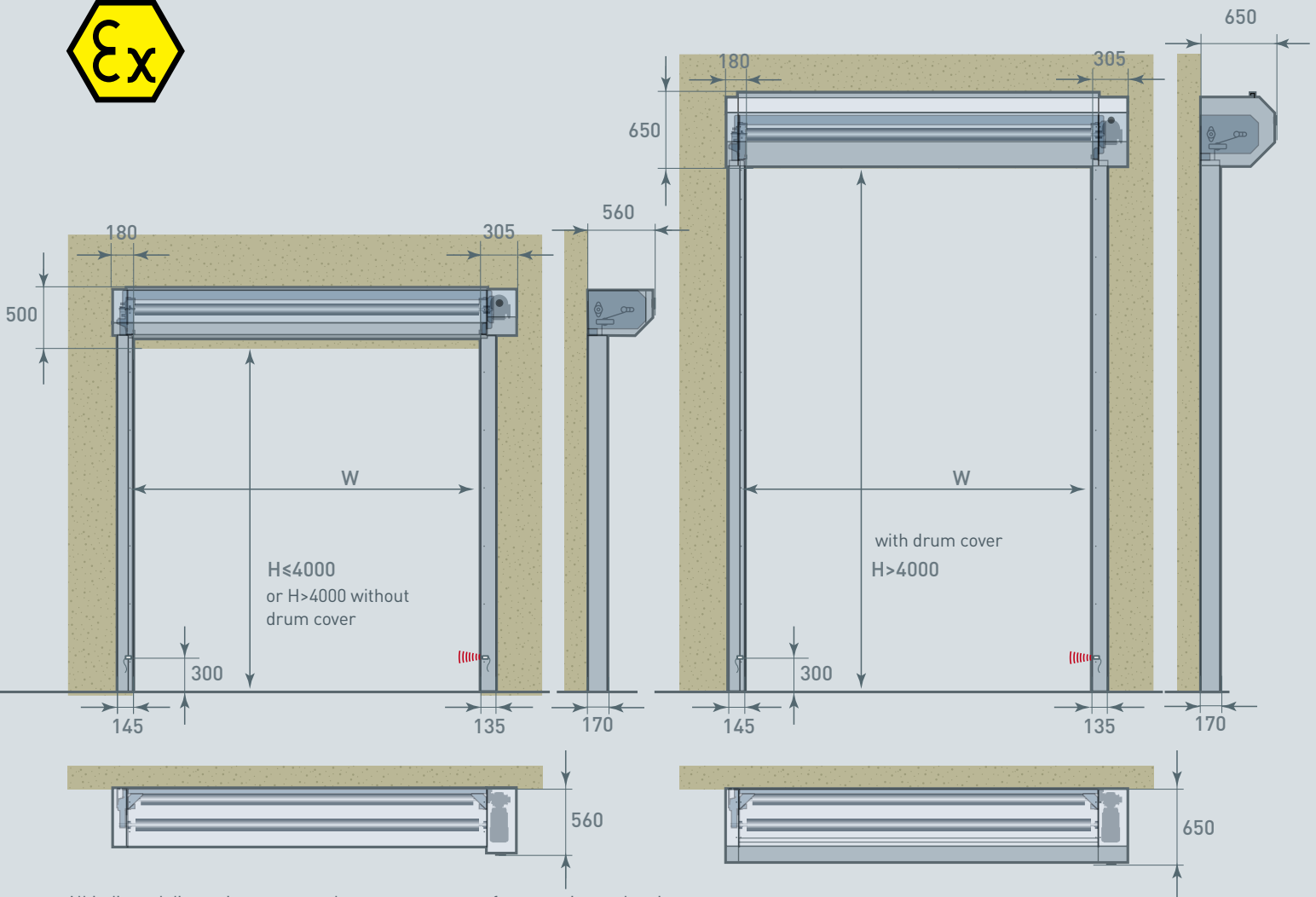

All indicated dimensions are net: the space necessary for mounting and maintenance has to be provided. Reduced dimensions: upon request.

REMARK: Based on the risk analysis of the environment, extra push buttons, detectors and covers might be required.



Dynaco Europe NV
 Waverstraat 21
 B-9310 Moorsel-Aalst (Belgium)
 Tel. +32 53 72 98 98
 Fax. +32 53 72 98 50
 info@dynacodoor.com
 www.dynacodoor.com

About Dynaco

Dynaco is the world leader in high speed door technology. It offers state of the art solutions for both commercial and industrial applications.

Founded in 1987, Dynaco has acquired an extensive expertise in high performance doors. Yet it continues to invest in order to exceed your expectations of quality and performance. A network of certified and dedicated partners ensures an optimal service to customers all over Europe. Worldwide, we rely on our license partners in Russia, Japan, Vietnam and Brazil.

Dynaco is part of the ASSA ABLOY Group, the world leader in access solutions. Every day, we help billions of people experience a more open world.